



Low Temperature Chillers

Air & Water Cooled Scroll, Semi-Hermetic,
& Screw Chiller Systems



**WE BUILD SYSTEMS THAT FOCUS ON ONE GOAL:
TO KEEP YOUR EQUIPMENT RUNNING!**

LOW TEMPERATURE



Why Choose Drake?



1/4 ton to 200 tons air-cooled and water-cooled chillers



Technical site review and needs assessment



Custom engineering for specific industries



Outstanding after-sale technical support

Drake Refrigeration, Inc. has been manufacturing industrial process chillers since 1972 and offers a complete line of air-cooled and water-cooled chillers from 1/4 ton to 200 tons. Drake designs custom process chillers to meet a customer's particular needs when a standard chiller won't work. By maintaining a cost effective, yet dependable product line with many custom options, our client base has grown to include many industries and applications.

With close to 50 years of experience, we bring our expertise and engineering to every chiller we design, fabricate, and test to make sure we're providing reliability and ease of operation without sacrificing either. Our systems can be built to handle varying loads, multiple pieces of equipment, narrow temperature bands, near freezing water, low exiting temperatures, low and high ambient conditions, high return temperatures, corrosive environments, and many others. Drake is the industry leader in the design and manufacturing of industrial process chillers, and our chillers are available for quick delivery. Our business is built on creating custom engineered solutions for your specific cooling needs, with outstanding after-the-sale technical support and customer service.



Low Temperature Chillers

www.drakechillers.com

Low Temperature Chillers

Low temp chillers often come with complexities that other chiller companies avoid – but not Drake. We're different because we take the time to understand your process and operating conditions before making an equipment selection. So, whether you need an air-cooled low temp chiller that relies on ambient air to keep your process cool or a water-cooled low temp chiller that relies on water from an external cooling tower to chill your process, Drake will engineer an affordable solution that will meet your specifications.



PACL1200D6-T4-T



Drake Low Temp Chillers vs. Off-the-Shelf Chillers

Rapid Pull Down

Low-temp applications often require large pull-downs, and many competitors only design for the final temperature considerations, which causes highly inefficient chiller operation. We've designed our systems to allow for quick and efficient pull-downs through the entire temperature range. Thanks to our electronic expansion valves (EEVs), our low-temp chillers maintain a constant superheat with no human interaction.

Oil Management

Anyone with experience in low-temp chillers knows that lack of oil return can plague the operation of even the simplest system. Drake takes all the necessary measures to ensure full oil returns to the compressor without requiring a service technician. Our chillers ensure the proper amount of oil remains where it should: in the compressor. Oil management systems include an oil separator, oil filter, solenoid valve, ball valves, and oil pressure sensor. Oil is the lifeblood of a chiller, and with so much attention to detail in this area, it's no wonder that our low-temp chillers have incredible longevity.

A Vast Array Of Cooling Types

At lower temperatures, many standard antifreeze fluids become too viscous to pump. We design our low-temp chillers to meet your specific fluid. With us, you never have to de-rate chiller performance because we factor in fluid properties to ensure that our evaporators are sized for 100% efficiency. It's just one more way we engineer solutions for optimal performance and efficiency.

Low Mass flow rate creates the need for oil management systems

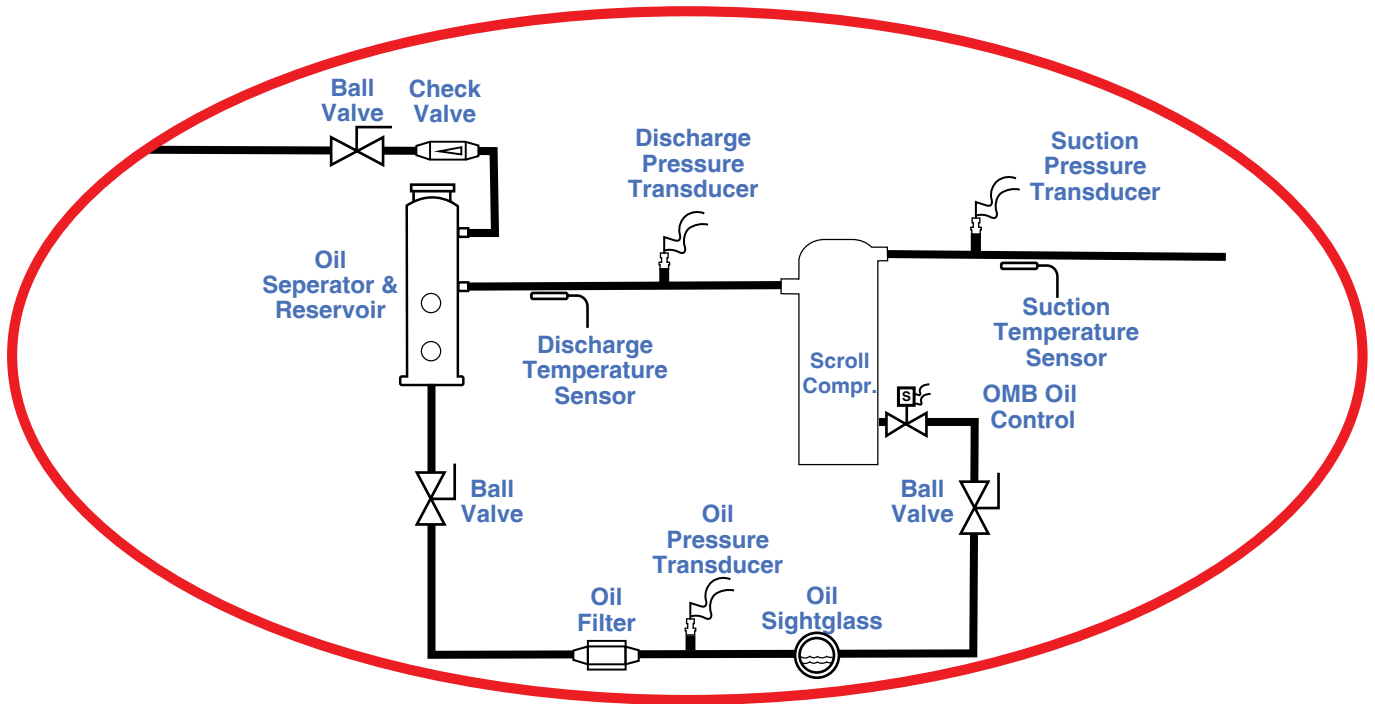

Where To Find Drake

Drake is sold through most refrigeration wholesalers, so you are working with suppliers and contractors that you know and trust. Representatives are located throughout North, Central, and South America so you can get the support you need for all stages of the project.

Drake engineers are available to discuss your project directly and our service goes well beyond the start up of the equipment. The Drake service team is able provide over the phone technical support and remote login capabilities during the entire life cycle of a Drake chiller system. With over 40 years of experience delivering engineered solutions to a wide array of industries, Drake has the knowledge and know-how to design the ideal industrial process chiller for your application.

Drake build systems that focus on one goal: To keep your equipment running!

Call us today at 888-289-7299 to get started building your custom chiller.



888-289-7299
www.drakechillers.com

Manufactured in the USA.