



®

TSR600S (POLY)

600 GALLON POLYETHYLENE RECIRCULATION TANK SECTION

DIMENSIONAL DRAWINGS

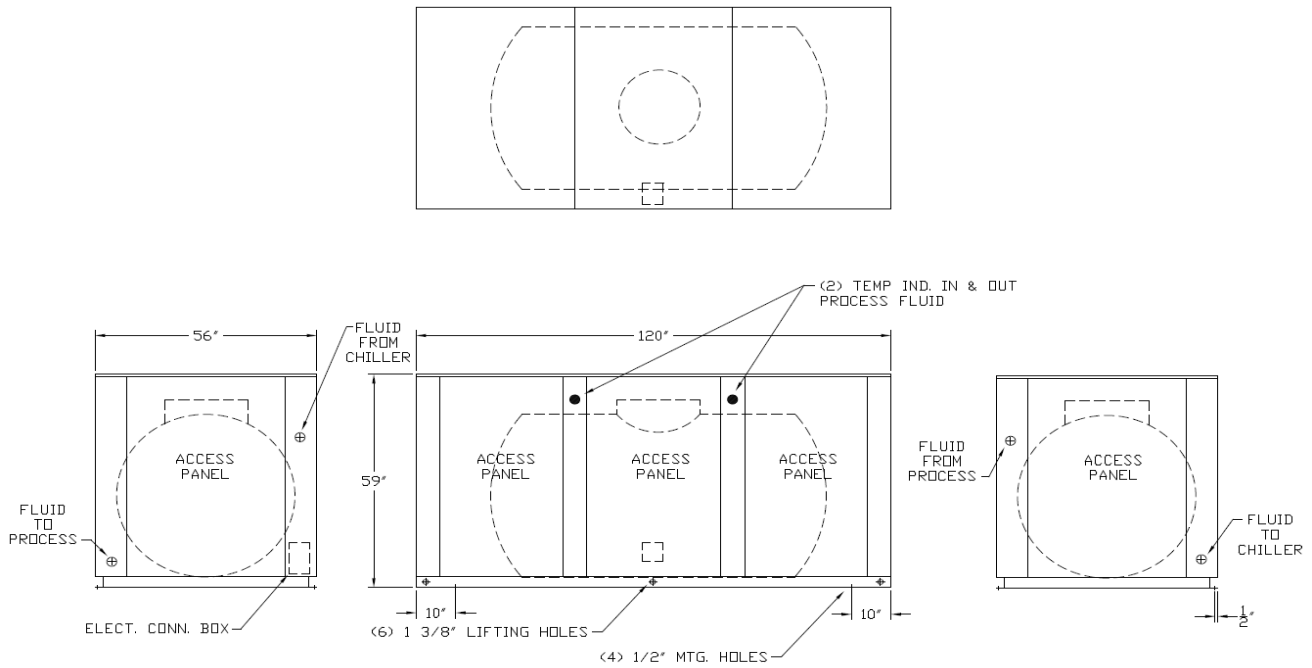

LENGTH	WIDTH	HEIGHT	FLUID CONNECTIONS	TANK CAPACITY	WEIGHT
120"	56"	59"	4" F-NPT	600 GAL	560 LBS

DRAKE REFRIGERATION INC
 2900 SAMUEL DRIVE
 BENSLEM, PA 19020
 (888) 289-7299
www.drakechillers.com

*ALL INFORMATION **FOR REFERENCE ONLY**



TSR600S (POLY)

600 GALLON POLYETHYLENE RECIRCULATION TANK SECTION

STANDARD FEATURES	
FEATURE	BENEFIT
Listings	ETL 3046941, UL STD 1995, CAN/CSA STD, C22.2 No. 236
Polyethylene Tank Section	High quality, insulated tank with vent & drain connections and pressure relief valve for proper maintenance
Insulated Process Fluid Lines	Maximum thermal efficiency
Stainless Steel Recirc. Pump	1/3 HP to 3 HP on board pumps in multiple configurations & options
Fluid Piping Y Strainer	Cleanable, stainless steel strainer for filtration from process
Painted Galvanized Steel Metal Cabinet	Sturdy, corrosion resistance, professional appearance
Process Fluid Temperature Indicators	24 V L.E.D. water resistant displays for monitoring temperatures through tank
Factory Tested	Ensures the unit meets the customer's performance designed criteria and arrives in working order
NEMA 3R Rated Electrical	Indoor/outdoor use

AVAILABLE OPTIONS	
OPTIONS	AVAILABLE
Process Pump	Fused, stainless steel process pumps with upgrades such as dual auto/manual changeover
Electrical	Seal-tight electrical connections
Fluid Piping Upgrades	Flow meters, pressure gauges, low flow bypass valves, and more
Tank Upgrades	Stainless steel, welded tank
Cabinet Upgrade	Stainless steel sheet metal cabinet
Other	Low level indicators with dry contacts, city water add-ons, heaters, etc.
<i>More options and customization available, contact factory for information: (888) 289 - 7299</i>	

AVAILABLE MODEL TANK SECTION REFERENCE
TSS (Storage Tank, 2 Connections) --- TSR (Recirculation Tank, 4 Connections, Recirc. Pump)

AVAILABLE MODEL NUMBER VOLTAGE REFERENCE
S2 (208-230/1/60) --- T3 (208-230/3/60) --- T4 (460/3/60)

PRODUCT INFORMATION			
MODELS AVAILABLE	RECIRCULATION PUMP		
	MODEL	HP	FLA
TSR600S-S2	3MS1H1A4	3	13.6
TSR600S-T3	3MS1H2A4		9
TSR600S-T4			4.5

DRAKE REFRIGERATION INC
 2900 SAMUEL DRIVE
 BENSLEM, PA 19020
 (888) 289-7299
www.drakechillers.com

*ALL INFORMATION **FOR REFERENCE ONLY**